

DEMA Nitro Express Ware Wash Chemical Dispenser

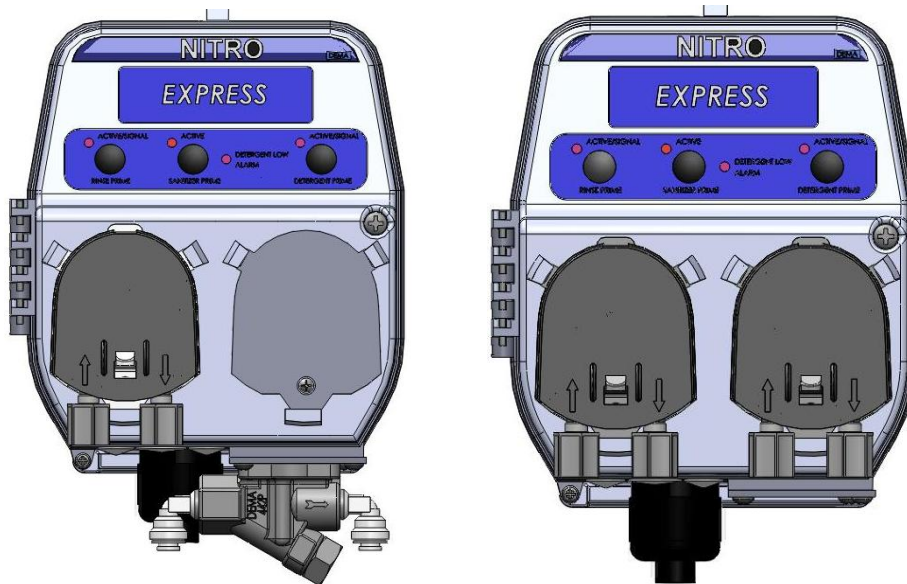

Overview

The DEMA Nitro Express is an analog ware wash dispenser designed to dispense cleaning chemicals into ware wash and dish machines. The unit is triggered by a ware wash machine. Programming is accomplished through the use of potentiometers and dip switches.

Warnings



Installation of DEMA products must meet all applicable electrical codes and regulations established by national, city, county, parish, provincial or other agencies. It is possible that electrical codes and regulations require that a certified electrical contractor or engineer perform the electrical installation. For questions, contact a certified electrician.



All installations must conform to local plumbing codes and use approved backflow prevention devices. A pressure indicating tee is to be installed with existing faucets according to local plumbing codes in the state of Wisconsin and any other state that requires the use of a pressure indicating tee.

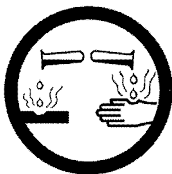

ALWAYS WEAR PROTECTIVE CLOTHING AND EYEWEAR WHEN WORKING WITH CHEMICAL PRODUCTS.

Packing List

X = included in kit

Part Number	Description	NE.DL.A	NE.LL.A	NE.DLL.A	NE.LLL.A
904.8T	RINSE CHECK VALVE ¼" OD TEFLON BALL	X	X	X	X
80.55	LIQUID DETERGENT FEED INJECTION ELBOW		X		X
81.312.1	SPLIT PICK UP TUBE STIFFENER	1	2	2	3
25.68.20	20 FT ¼" OD LDPE TUBING	X	X	X	X
C.12B	CONDUCTIVITY CELL	X	X	X	X
100.12.SV1	VINYL RINSE TUBING	X	X	X	X
58.5	OVERFLOW ELBOW KIT – DRY DETERGENT	X		X	
904.8KY	RINSE CHECK VALVE ¼" COMP X 1/8" NPT KYNAR			X	X
81.16.1	TIE WRAPS 8" LONG	5	5	8	8
I974	INSTRUCTION SHEET	X	X	X	X

Operational Requirements

For indoor use only	
Main Power	100-265VAC 50/60 Hz 1.5A
Motor/Solenoid Rating	24VDC
Enclosure Material	ABS
Environmental Temp.	0-40°C 32-104°F
Product Weight	1.8 kg 4 lbs
The integrity and operational characteristics of this unit are not guaranteed outside the above mentioned parameters. Use of this unit outside of these parameters nullifies warranty.	

This unit will only accept up to 265 VAC. It cannot accept over this amount. If more than 265 VAC is supplied to this unit, critical damage will occur.

Overall Size

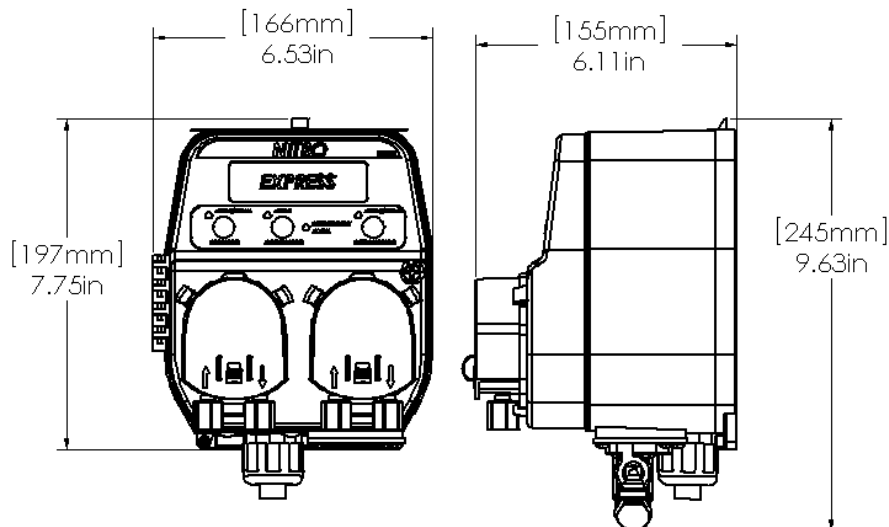

Replacement Parts List

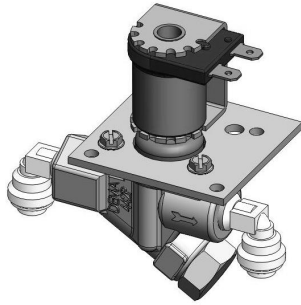

81.316.6 NITRO/NITRO EXPRESS DETERGENT VALVE CONV. AND REPLACEMENT KIT
58.104.2- J.G. ELBOW FITTING FOR VALVE

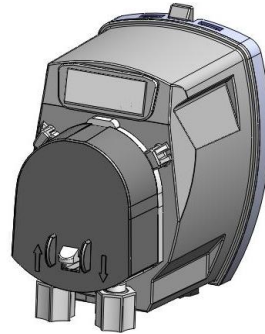

81.316.7 NITRO/NITRO EXPRESS SANITIZER PUMP CONVERSION KIT INCLUDING CONTROL BOARD (NOT SHOWN)

O.ADC NITRO/NITRO EXPRESS SANITIZER PUMP WITH TUBING AND ACCESORIES

Model shown is of a NE.LL.A

NO.	KIT NO.	DESCRIPTION
1	81.316.1	NITRO/NITRO EXPRESS POWER SUPPLY REPLACEMENT KIT (TRIGGER OUTPUT TRANSFORMER)
2	81.316.2	CONTROL BOARD NITRO EXPRESS FOR 2 PRODUCT (DETERGENT/RINSE)
	81.316.3	CONTROL BOARD NITRO EXPRESS WITH SANITIZER (3 PRODUCT)
3	81.316.4	NITRO/EXP. DETERGENT PUMP HEAD AND MOTOR CONV. AND REPLACEMENT KIT
	81.316.10	NITRO/NITRO EXPRESS DETERGENT MOTOR ONLY REPLACEMENT KIT
	81.316.6	NITRO/NITRO EXPRESS DETERGENT VALVE CONVERSION AND REPLACEMENT KIT
4	81.316.5	NITRO/NITRO EXPRESS RINSE PUMP HEAD AND MOTOR REPLACEMENT KIT
	81.316.11	NITRO/NITRO EXPRESS RINSE MOTOR ONLY REPLACEMENT KIT
5	81.316.8	NITRO/NITRO EXPRESS DETERGENT PUMP HEAD ONLY REPLACEMENT KIT
	81.316.9	NITRO/NITRO EXPRESS RINSE PUMP HEAD ONLY REPLACEMENT KIT
	25.21.4	SINGLE SQUEEZE TUBE REPLACEMENT
	25.21.5	BULK (5) SQUEEZE TUBE REPLACEMENT
6	L1115	MEMBRANE LABEL
7	81.275.1	MOUNTING BRACKET

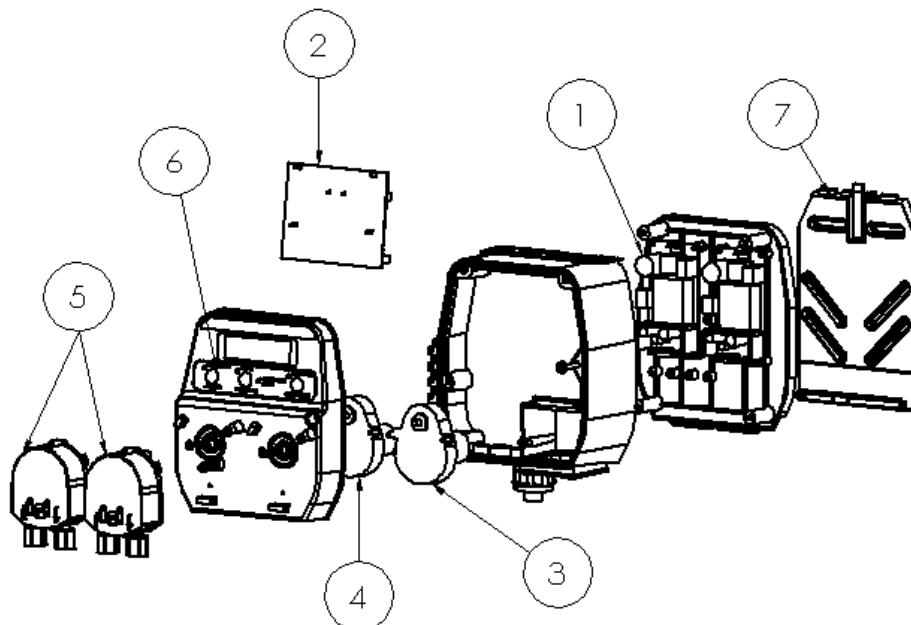

Installation



WARNING: INSTALLATION OF DEMA PRODUCTS MUST MEET ALL APPLICABLE ELECTRICAL CODES AND REGULATIONS ESTABLISHED BY NATIONAL, CITY, COUNTY, PARISH, PROVINCIAL OR OTHER AGENCIES. IT IS POSSIBLE THAT ELECTRICAL CODES AND REGULATIONS REQUIRE THAT A CERTIFIED ELECTRICAL CONTRACTOR OR ENGINEER PERFORM THE ELECTRICAL INSTALLATION. FOR QUESTIONS, CONTACT A CERTIFIED ELECTRICIAN.

ALL ELECTRICAL POWER MUST BE TURNED OFF TO THE HEATING ELEMENTS AND DISH MACHINE PRIOR TO BEGINNING INSTALLATION

UNIT MUST BE GROUNDED (EARTHED).

Mounting the Nitro Express

1. Remove mounting bracket from dispenser.
2. Mount the bracket in an appropriate place on a wall.
3. Slide the dispenser onto the bracket and attach the secure screw on the bottom left corner of the dispenser.

Setting up the Nitro Express and the Dish Machine

1. Locate the electrical connection point. The input power may be 100V – 265 V 50/60 Hz. Check with the manufacturer of the machine to determine if there are dedicated terminals available for installation.
2. Properly ground the dispenser to earth ground.
3. If the Nitro Express will be operating in the concentration mode, locate the proper position for the DEMA C-12B probe in the wash tank. The probe must be installed below the water level, normally 1-2” from the bottom of the tank, and must be kept away from heating elements, pump intake, drains and incoming water supply.
4. Install the detergent injection bulkhead fitting (80-55) above the probe (if a probe is used) to obtain a rapid reading of all chemicals entering the wash tank.
5. Install the rinse line injection fitting (904-8T) into the rinse line tap provided by the manufacturer of the machine. If a tap is not provided, follow the manufacturer’s recommendations for installing this fitting.
6. Install the sanitizer injection fitting (904-8KY) (if sanitizer is used) into the rinse line tap provided by the manufacturer of the machine. If a tap is not provided follow the manufacturer’s recommendations for installing this fitting.

Connecting the Chemical Tubing to the Nitro Express

1. After mounting the dispenser, measure the length of tubing needed to go from the dispenser to the chemical containers. The detergent tubing (25.68.20) is opaque in color and has a larger inside diameter than the rinse and sanitizer tubing (100.12.SV1) which is clear in color and has a small inside diameter.
2. Cut the tubing to the length required and, if desired, place the pickup tube on the tubing before placing in the chemical container.
3. Measure the length of tubing needed to go from the dispenser to the chemical injection point on the machine.
4. Cut the tubing to the length required to reach the bulkhead fitting or chemical injection point on the machine.

Clasp Close Pump Heads

The pump heads have an added feature which will help to ensure the pump head is installed properly. When pushing the pump head on be sure to see the clip is fully covering the notch as seen in the first picture. If the tab is not fully engaged, there is a possibility of it popping off the pump head as seen in the second picture.



Wiring the Nitro Express to the Dish Machine

The following diagram is included to help to install the wires in the correct places for proper power for the unit.

WARNING: ONLY UP TO 265 VAC SHOULD BE SUPPLIED TO THIS UNIT. ANYTHING OVER THAT AMOUNT WILL CAUSE CRITICAL DAMAGE TO THE UNIT.



WARNING: For safety purposes disconnect main power to the dish machine before wiring trigger signals to the Nitro Express. Connect power to the Nitro Express per the dish machine manufacturer’s recommendations.

UNIT MUST BE GROUNDED (EARTHED).

The following steps will help to insure the proper wiring of the unit. The unit should be triggered to power on from the dish machine that it is being used in conjunction with. DEMA Engineering does not recommend powering the unit separately from the dish machine. The following three steps will insure that the unit only receives power when it is necessary to have power to run the setup that is programmed in the unit.

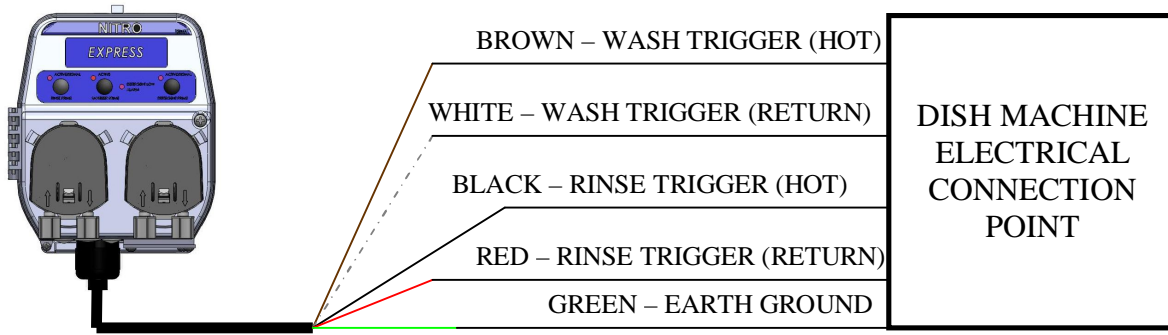

1. Connect the wash trigger (white and brown wires) to the appropriate wash trigger output (between 100 and 265 VAC 50/60Hz) as recommended by the dish machine manufacturer.
2. Connect the rinse trigger (black and red wires) to the appropriate rinse trigger output (between 100 and 265 VAC 50/60 Hz) as recommended by the dish machine manufacturer.
3. Make sure to connect the earth ground (green wire) to the ground connection on the dish machine as recommended by the dish machine manufacturer.

If there is ever any question about the connection to the dish machine, please check with the dish machine manufacturer to see where the proper trigger connection points are located before installing the trigger connection wires.

Below is a wiring diagram for the unit. This is the internal wiring of the unit.

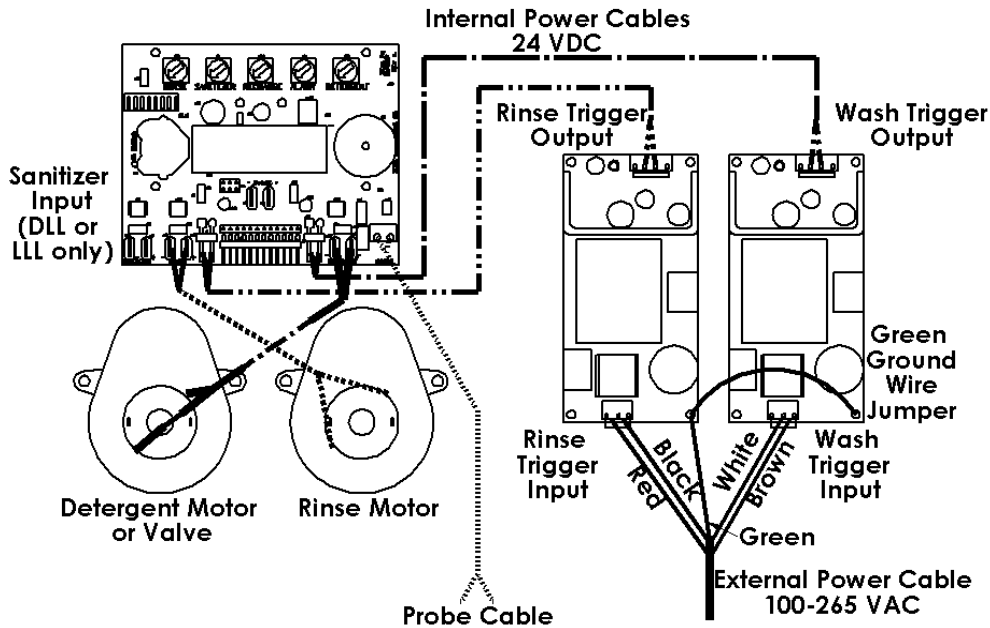

Programming the Nitro Express

Programming is done through the setting of dip switches and potentiometers (knobs). The following states how to program the Nitro Express.

Changing Settings

When switches are changed or pots are turned, the settings will take effect immediately. In the case that the unit is processing the previous settings, it will finish the current cycle before the new setting is used. If the Probe/Probeless or Door/ Conveyor Settings are changed, the unit will start the cycle over immediately.

Dip Switches

The following diagram illustrates what the different switches refer to so that the Nitro Express can be set up for the proper situation.

The dip switches are set up so that the “up” position is “on” and the “down” position is “off”.

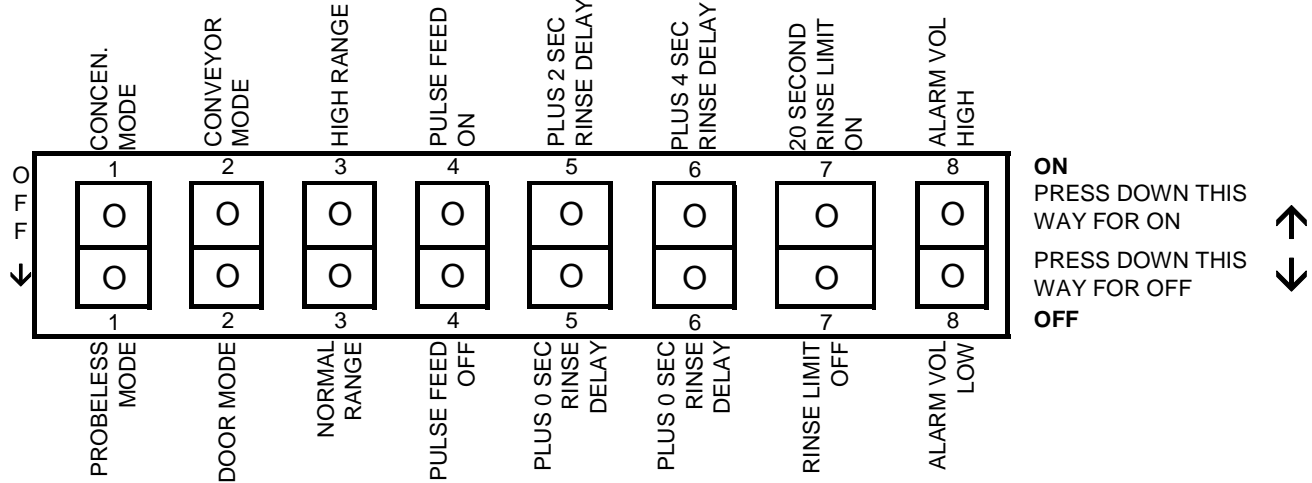

Potentiometers (Knobs)

The potentiometers can be set according to the following charts. Each of the next four figures will outline various configurations that are possible. For more information on these configurations consult pages 5-6 to see how to set up the dip switches for the configurations.

Rinse/Sanitizer Settings

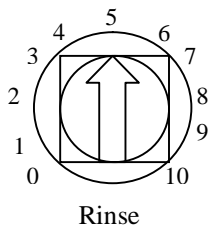

Rinse

The Rinse and Sanitizer knobs control the same setting whether in probe or probeless mode and in door or conveyor mode. They control the speed of the rinse and sanitizer pump.

The table to the right has approximate values for the pump rate at different settings of the knob.

Only the DLL and LLL models have a sanitizer potentiometer.

RINSE/ SANITIZER SETTING	PUMP RATE
0	0 ml/min
2	8.5 ml/min
4	27 ml/min
6	33 ml/min
8	40 ml/min
10	43 ml/min

Probeless and Door Configuration

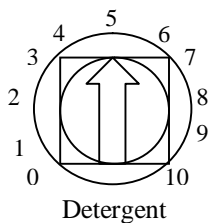

Detergent

Initial Detergent Charge – The detergent knob sets the time the detergent pump will run or detergent valve will remain open during an initial charge. The time can be set from 0-60 sec.

The initial charge is activated in one of two ways.

1. It can be activated by 1 hour of elapsed time where no triggers have activated the dispenser.
2. With the rinse limit turned on (switch 7) and a rinse trigger active for more than 20 seconds, an initial charge will be dispensed.

DETERGENT INITIAL CHARGE SETTING
0-60 sec
0-170 ml
0-5.75 oz

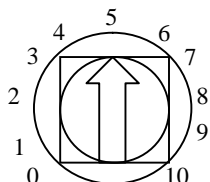

Alarm (Dead Cycles)

Dead Cycles – The alarm knob sets the number of cycles no detergent is dispensed before a recharge portion of detergent is added to the machine.

The table to the right has the different settings for the Dead Cycle count corresponding to the knob setting.

ALARM SETTING	DEAD CYCLES
2	0
4	1
6	2
8	3

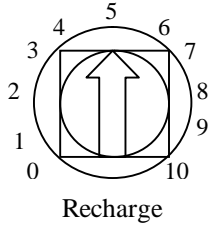

Detergent Recharge – The recharge knob sets the pump run time for a recharge. The recharge takes place after the dead door cycles have been reached.

The table to the right explains the differences in the Normal and High range setting (switch 3).

RECHARGE	
Normal Range	
0-30 sec	0-85 mL
High Range	
0-60 sec	0-170 mL

Probeless and Conveyor Configuration

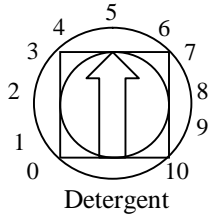

Initial Detergent Charge – Same as Probeless and Door above.

DETERGENT	
INITIAL CHARGE SETTING	
0-60 sec	
0-170 ml	
0-5.75 oz	

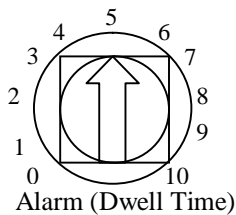

Dwell Time – The alarm knob sets the amount of time before a detergent recharge portion is dispensed.

The table to the right has the different settings for the dwell time corresponding to the knob setting.

ALARM	
DWELL TIME	
0-180 sec	

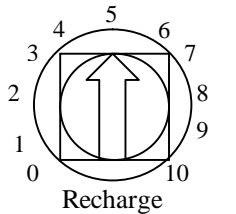

Detergent Recharge – The recharge knob sets the pump run time for a recharge. A recharge will take place after the dwell time has elapsed.

The recharge amount has two settings – normal and high (switch 3 sets the range).

RECHARGE	
Normal Range	
0-30 sec	0-85 mL
High Range	
0-60 sec	0-170 mL

Probe (Concentration) Configuration

The settings for the probe configuration are the same when the dispenser is being used in door or conveyor mode.

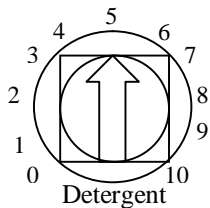

Detergent Concentration Level – The detergent knob sets the concentration level or set point. DEMA Engineering recommends starting in normal range (set using switch 3) and using a titration kit to achieve the desired detergent concentration level.

DETERGENT	
Concentration	
Normal Range	
High Range	

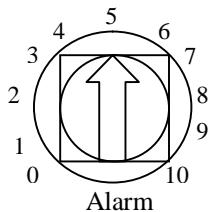

Alarm Time– The alarm knob sets the time that the dispenser will allow itself to reach the detergent concentration level. An audible alarm will sound if the concentration level is not reached in the set time.

ALARM	
TIME	
0-180 sec	

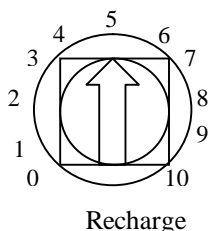

Recharge – The recharge knob has no function in probe or concentration mode.

Troubleshooting

(Some models may not include all items listed below)

Symptom	Probable Cause	Remedy
No power is being supplied to the unit	<ol style="list-style-type: none"> 1. Trigger Cables connected to the wrong place on the machine. 2. Switch on bottom of unit is turned off. (Some units may not have a switch) 3. Power is not cycling on the machine properly. 4. Trigger/Power cable is damaged from installation. 	<ol style="list-style-type: none"> 1. Check wiring diagram for proper connection and contact dish machine manufacturer for correct trigger placement. 2. Make sure switch is turned on. 3. Check with the dish machine manufacturer if all power should have been restored to the unit to see if there is an issue with the machine. 4. Turn power to the dish machine off and inspect the cable for any possible damage done.
Pumps are not priming like they should be or not holding a prime	<ol style="list-style-type: none"> 1. Hole in the tubing from the chemical container to the pump head. 2. Hole in the squeeze tube in the pump head. 3. Fitting is not tight on the tubing 	<ol style="list-style-type: none"> 1. Check the tubing from the chemical container to the pump head for leaks by feeling the tubing for chemical that has leaked out. Replace the tube if necessary. 2. Replace the squeeze tube after inspecting it for a possible hole or leak. 3. Check both the inlet and outlet fitting and tighten if necessary to create a good seal.
Pump over feeding	<ol style="list-style-type: none"> 1. If in concentration or probe mode, Pulse feed may be turned off. 2. If in concentration or probe mode, probe cable may not be connected properly. 3. If a probe is being used, scale could be built up on the probe. 4. Dip switch is on High Range and pot is set for low range. 	<ol style="list-style-type: none"> 1. Check the dip switches and turn the pulse feed on. 2. Check the probe cable connection points and make sure it is connected properly. 3. Clean Probe. 4. Switch dip switch to low range or set pot to needed setting.
Pump under feeding	<ol style="list-style-type: none"> 1. If in concentration or probe mode, the probe cable may be shorted. 2. If a probe is being used, scale would be build up on the probe. 3. Dip switch is on low range and pot is set for high range. 	<ol style="list-style-type: none"> 1. Check the probe cable for any possible shorts and correct the issue where necessary. 2. Clean Probe. 3. Check the dip switches and switch to high range if necessary or set pot to needed setting.
Rinse/Sanitizer pump not running	<ol style="list-style-type: none"> 1. Speed turned off. 	<ol style="list-style-type: none"> 1. Check the pot to see the speed setting and make sure it is turned to the proper setting.

Warranty

Merchandise Returns

No Merchandise will be Returned for Credit Without DEMA'S Written Permission. Returned Merchandise Authorization Number is Required in Advance of Return.

Product Warranty

DEMA products are warranted against defective material and workmanship under normal use and service for one year from the date of manufacture. This limited warranty does not apply to any products that have a normal life shorter than one year or failure and damage caused by chemicals, corrosion, physical abuse, or misapplication. Rubber and synthetic rubber parts such as "o"-rings, diaphragms, PVC tubing, and gaskets are considered expendable and are not covered under warranty. This warranty is extended only to the original buyer of DEMA products. If products are altered or repaired without prior approval of DEMA, this warranty is void.

Defective units or parts should be returned to the factory with transportation prepaid. If inspection shows them to be defective, they will be repaired or replaced without charge, F.O.B. factory. DEMA assumes no liability for damages. Return merchandise authorization number must be granted in advance of returned units for repair or replacement (See "Merchandise Returns" above).