

## INTRODUCTION

The Encapsulator Plus dispenses a ready-to-use mix of chemical product and water to pot-and-pan sink or pre-soak applications. It operates from a single manual valve and delivers a consistent product mixture.

## THEORY OF OPERATION

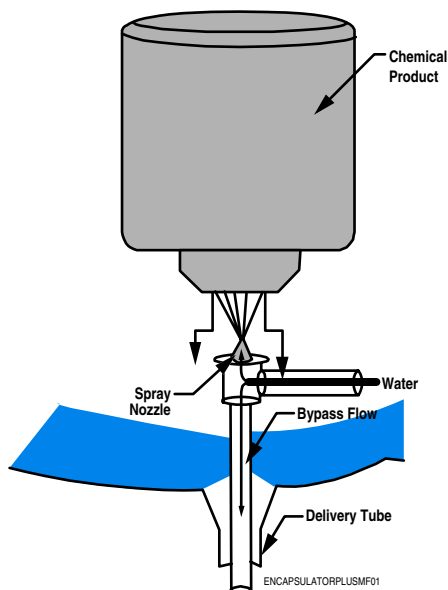

Figure 1. Theory of Operation

The dispenser diverts water in two directions; a small fixed amount to a spray nozzle, and an adjustable bypass amount down the delivery tube (refer to Figure 1). Water is lightly sprayed up into the product bottle. The concentrated mixture drains into the bowl, then down the delivery tube. This concentrated mixture is diluted to a ready-to-use stream by the bypass water.

You can increase or decrease product concentration by adjusting bypass flow (follow the procedures described later in **Adjusting the Concentration**). Water to the spray nozzle is fixed and cannot be adjusted.

## APPLICATIONS

The dispenser is specifically for pot-and-pan sinks (Solid model) or encapsulated powder products (Powder model). Different types of products require different spray nozzle assemblies.

### Misting Nozzle—Solid Model

The misting nozzle provides a fine mist onto the product, consuming 0.052 gallons (0.20 liters) of water per minute at 30 psi (2.1 bar).

### Misting Nozzle—Powder Model

The furnished black, slow-feed nozzle provides a spray onto the product, consuming 1.04 gallons (3.9 liters) of water per minute at 50 psi (3.44 bar).

## SPECIFICATIONS

### DIMENSIONS

Size	Height	Width	Depth
	18.5	10.5	8 inches
	47.0	26.7	20.32 cm

### WEIGHT

4.7 lbs (2.13 kg)

### EXTERNAL MATERIAL

Molded Polypropylene

### MOUNTING

Mounts directly to the wall through four mounting holes. #10 x 3/4" self-tapping screws and anchors supplied.

### OPERATING CONDITIONS

#### Incoming Water Temperature

100 to 130°F (38 to 54°C)

#### Water Supply

Pressure

Minimum: 20 psi (1.38 bar)

Maximum: 80 psi (5.5 bar)

Maximum Flow Rate: 4.5 gpm (17 liters/min)

### COMPONENTS

#### Nozzle Assembly—Solid Model

Misting Nozzle: 0.052 gpm (0.20 liters/min) at 30 psi (2.1 bar), brass

#### Nozzle Assembly—Powder Model

Slow Feed: 1.04 GPM (3.9 liters/min) @ 50 psi (3.44 bar)

Water Valve  
External, 1/2" ball valve

Vacuum Breaker  
Code-compliant air-gap type. Plastic

Safety Shield  
To cover nozzle when product bottle is removed

## PRODUCT APPLICATION—SOLID MODEL

Application  
Pot & Pan

Nozzle Type  
Misting Nozzle (brass)

## PRODUCT APPLICATION—POWDER MODEL

Application  
Pre-soak

Nozzle Type  
Black, slow feed, plastic

## INSTALLATION

### MOUNTING

Mount the dispenser to a wall or flat vertical surface above the wash sink or fill container. Remember that gravity is an important part of the delivery of product down through the base of the unit, so the bowl should be as level as possible.

After determining a mounting location, mount the unit with the supplied anchors and screws (or other suitable hardware).

Ensure that the unit is securely mounted to the surface! Product cannisters are heavy and placing them into bowls stresses mounting hardware.

### PLUMBING

Follow all applicable plumbing codes when installing the supply line to the dispenser. A temperature-regulating device should be installed to regulate water temperature if incoming water temperature exceeds 140°F (60°C).

To supply water to the unit, route 3/8" copper tubing from the supply line to the tube fitting attached to ball valve.

### ADJUSTING THE CONCENTRATION

Product concentration is adjusted by increasing or decreasing the amount of bypass water that flows into the sink or bucket. This is done by adjusting the spray assembly (clockwise or counterclockwise). Follow the procedures below to adjust concentration.

1. Hold in the safety shield and loosen the two screws holding the retainer ring in place (do not remove the screws).

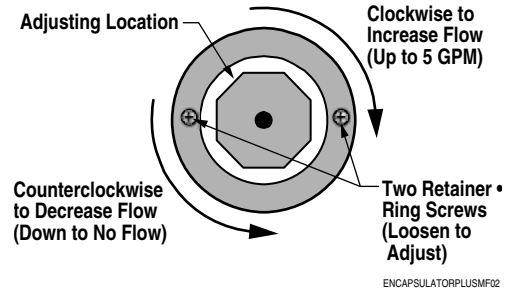

2. Turn the nozzle assembly to increase or decrease the flow, taking care not to completely unscrew the nozzle from the nozzle holder. Turning it clockwise increases the flow (to decrease the concentration) and turning it counterclockwise decreases the flow (to increase the concentration). The range of adjustment is from no flow to 5 gpm (19 liters/min). Refer to the table below for adjustment parameters.

**NOTE** *The dispenser is shipped with valve set for maximum bypass flow.*

### Bypass Flow at 30 psi (2.1 bar)

Adjustment Position (To Clockwise)	GPM
Fully Closed	0
1 Turn	1.5
2 Turns	3.0
3 Turns	4.0
Fully Open	5.0

3. When the flow has been adjusted, tighten the screws and resume operation.

### OPERATION

**WARNING!** *Check the incoming water supply temperature. Any thermostat setting of the water heater that is above 120°F (48.9°C) may cause accidental scalding, severe burns or other injuries.*

The dispenser is manually operated by the external ball valve. When the knob is turned vertically, the valve opens to allow water to enter the unit. When turned horizontally, the valve closes, stopping the water flow.

To Operate:

1. Prepare the sink under the dispenser before turning the valve to fill.
2. Turn the valve knob to the vertical position. The unit continues to operate until the valve is turned off.
3. When the sink is full, turn the valve knob to the off (horizontal) position.

# MAINTENANCE & TROUBLESHOOTING

## PREVENTATIVE MAINTENANCE

To keep the dispenser operating properly, it is important to check for product buildup around the spray mechanism and in the drainage area, and thoroughly clean if necessary.

Periodically check water temperature to ensure it is within the specified range.

## TROUBLESHOOTING

The dispenser is a relatively simple device and problems are minimal. Refer to the table below for common problems and their solutions.

Symptom	Possible Cause	Corrective Action
No water flow to unit.	Supply valve is turned off.	Turn supply valve on.
	Temperature Regulator valve is turned off.	Turn on Temperature Regulator valve.
No water flow through spray nozzle.	No water flow to unit.	Perform the above procedures.
	Nozzle is clogged.	Remove and clean the nozzle.
Not enough water flow into the sink, or mixture is too rich.	Nozzle assembly needs adjusting.	Follow the procedures for adjusting concentration.
Too much water flow into the sink, or low concentration.	Nozzle assembly needs adjusting.	Follow the procedures for adjusting concentration.

## MAINTENANCE

### Cleaning the Nozzle Assembly

Through time and use, buildup of residue can clog the nozzle, affecting spray efficiency. Also, debris can build up inside the nozzle assembly. Follow these procedures to properly remove and clean the nozzle.

Remove product canister and close water supply valve on unit before servicing.

1. Hold the safety shield in and remove the two screws holding the retainer ring (be careful not to drop the screws in the bowl). Lift the entire spray assembly from the unit. Be careful not to lose the O-ring.
2. If you have the misting nozzle, use a 13/16-inch wrench and an 11/16-in wrench to loosen and remove the two halves of the metal assembly. Remove the screen filter and completely clean the inside of all debris and residue and reassemble. If you have the plastic nozzle, unscrew it and clean all debris and residue from the inside.
3. Thoroughly clean the exterior of the nozzle and reassemble.
4. Place the O-ring into its groove and put the nozzle assembly into the manifold opening.

5. Replace the two screws on the retaining ring (take care not to drop the screws into the unit).
6. Adjust the nozzle as needed (refer to adjustment procedure earlier in this manual).

### Replacing the Nozzle Assembly

If the nozzle assembly gets damaged and needs to be replaced, follow the cleaning procedures above to remove the assembly and remove the damaged parts as required. When doing this, ensure that the spool is screwed sufficiently on to the nozzle holder to prevent it from bottoming in the manifold assembly.

Complete Unit	Beta Code #
Encapsulator Plus Solid w/Misting Nozzle	098780
Encapsulator Plus Solid Powder w/Slow Feed Nozzle	098781

### Recommended Spares

Complete Nozzle Assembly (Solid)	021432
Complete Nozzle Assembly (Powder)	1201621
Nozzle Cap, Tip, Retaining	017413
Nozzle Screen Assembly	021441
Upper Nozzle Insert (Solid)	057720
Upper Nozzle Insert (Powder)	094414
Bypass Valve O-ring	057059
Spool Valve	057718
3/8" OD x 8' Copper Tubing	1201057
Vac Brkr Repair Kit	093705
Valve, Ball, 3/8"	096398
Screw, Retaining ring	043839
Tubing, Discharge, Clear Vinyl (order by the foot)	035513
Cover Label	1201512

### Recommended Option

Temperature Regulating Device	034281
-------------------------------	--------

## TECHNICAL ASSISTANCE

If you require technical assistance or additional product technical information, contact the appropriate Technical Services Department (see contact information at the end of this document).

## PRODUCT REPAIR

If you need to return an item for repair, you must call or write to obtain a Return Authorization (RA) number **before** you may return the product. The Customer Service Department will issue a unique RA number for any product that satisfies the Warranty requirements. Multiple items in a single shipment will not normally require multiple RA numbers, but always make sure that the Repair Department knows the entire extent of your shipment in case this general rule doesn't apply. Refer to this number in all of your documentation, prominently display it on the outside of the shipping container, and refer to it if you need to call for information about the status of the repair.

It is very helpful to the Repair Department if you include in the shipping container a description of the problem, symptoms, failure or abnormality that precipitated the equipment's return.

Failure to obtain an authorization number before sending an item in for repair or replacement may seriously delay the repair and/or return of your equipment.

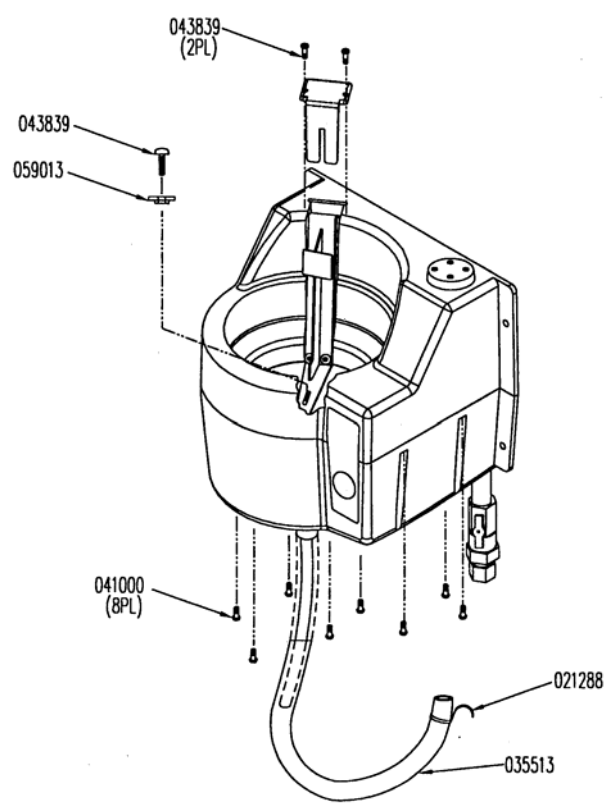
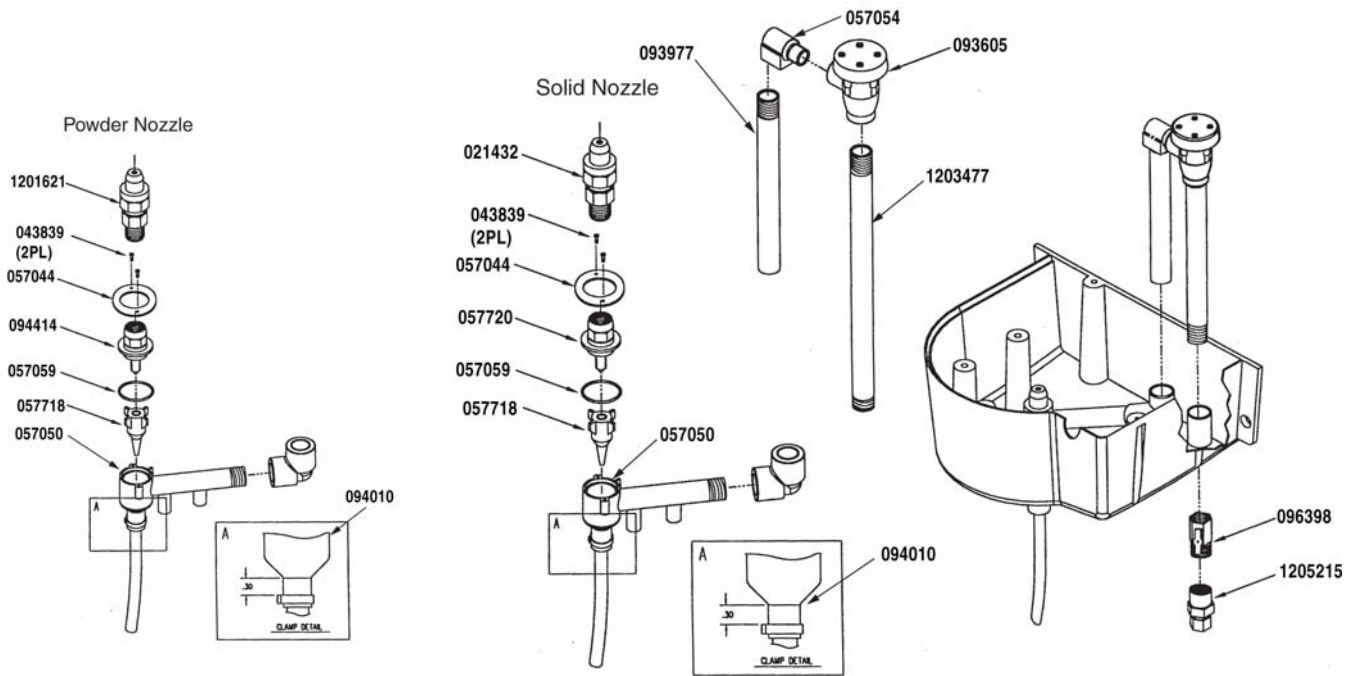

**Beta Technology**  
 2841 Mission Street  
 Santa Cruz • CA  
 U.S.A. • 95060

TEL • 831 • 426 • 0882  
 TEL • 800 • 858 • 2382  
 FAX • 831 • 423 • 4573  
 FAX • 800 • 221 • 8416

TEL (U.S. and Canada) • 800 • 468 • 4893  
 TEL (outside U.S. and Canada) • 410 • 228 • 1292  
 sales@beta-technology.com

Customer Service

Tech Support

Online Ordering: <http://www.beta-technology.com>

**Beta Technology**

4 Finway, Dallow Road  
 Luton LU1 1TR  
 United Kingdom

Freephone • 0800 • 052 • 4726  
 Tel • +44(0) • 1582 • 528600  
 Fax • +44(0) • 1582 • 528111  
 Freephone • 0800 • 052 • 4726  
 VAT REG.NO.BG.354 - 09975 - 44

europa.sales@beta-technology.com