

EFFECTIVE: MAY, 2008

American Dish Service

ADS HIGH TEMP SINGLE RACK DISHMACHINE MODEL: HT-25

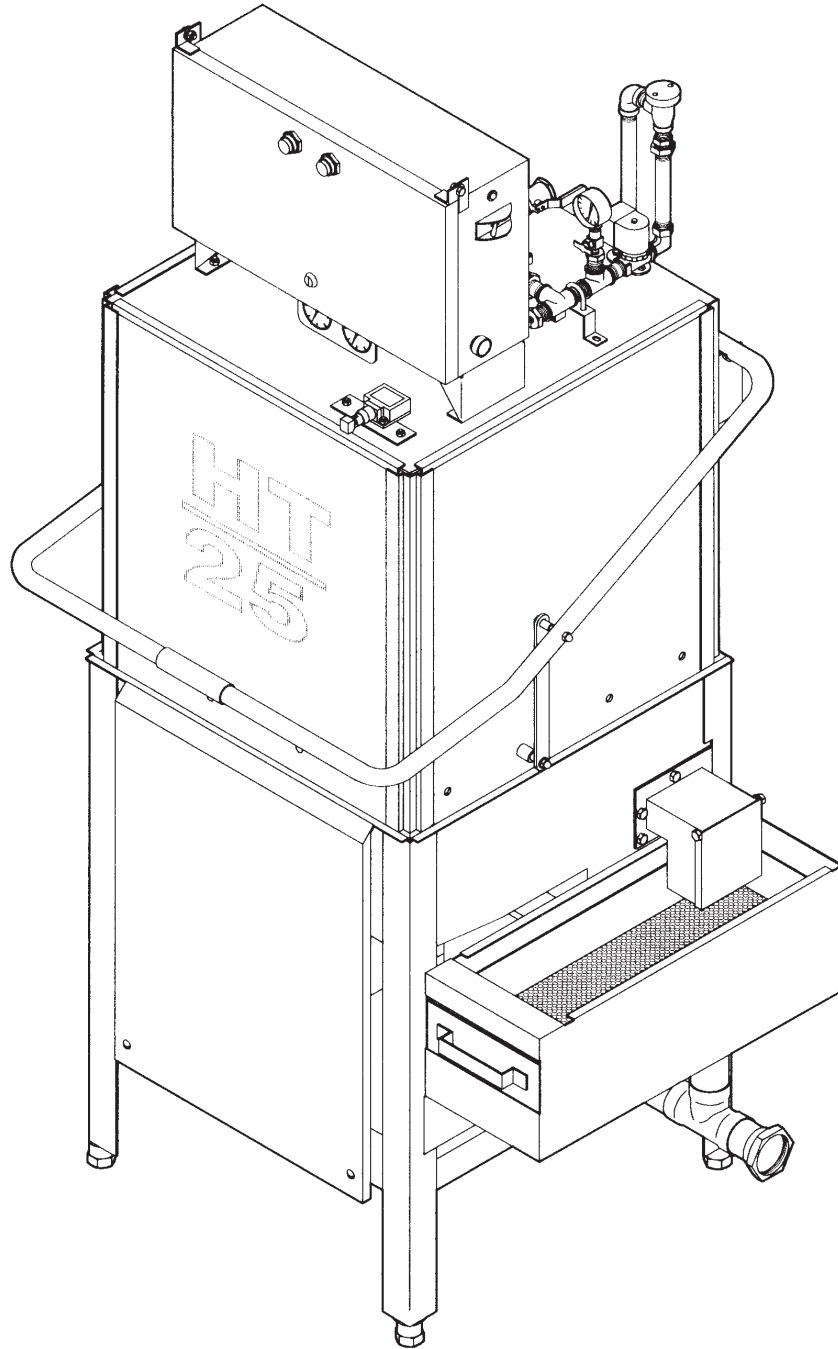

PARTS MANUAL

900 Blake Street
Edwardsville, Kansas 66111
(913)-422-3700

© 05/08

311-0060
HT-25 High Temp
Dishwasher

American Dish Service

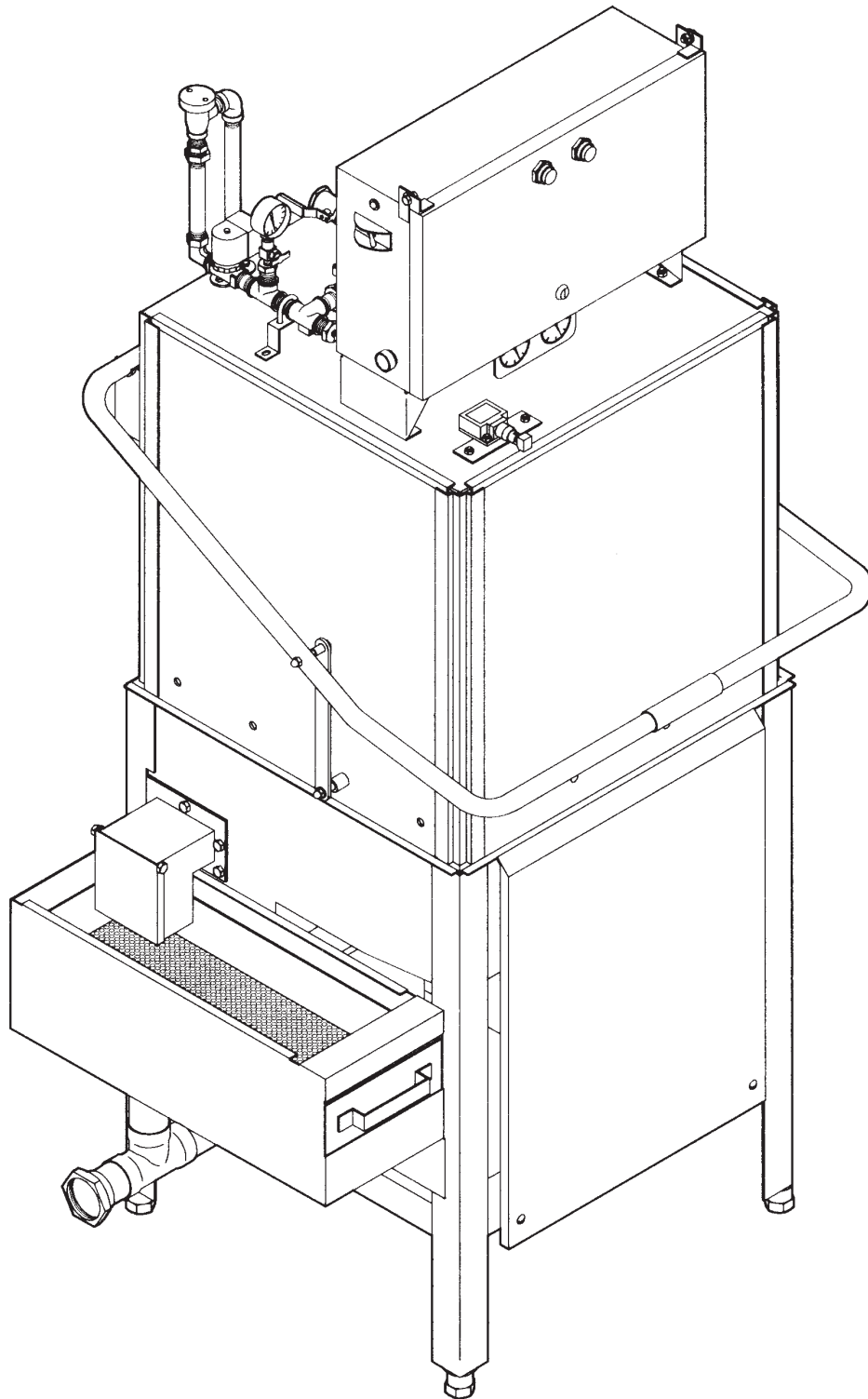

361-0100
Cabinet Assembly
HT-25

American Dish Service

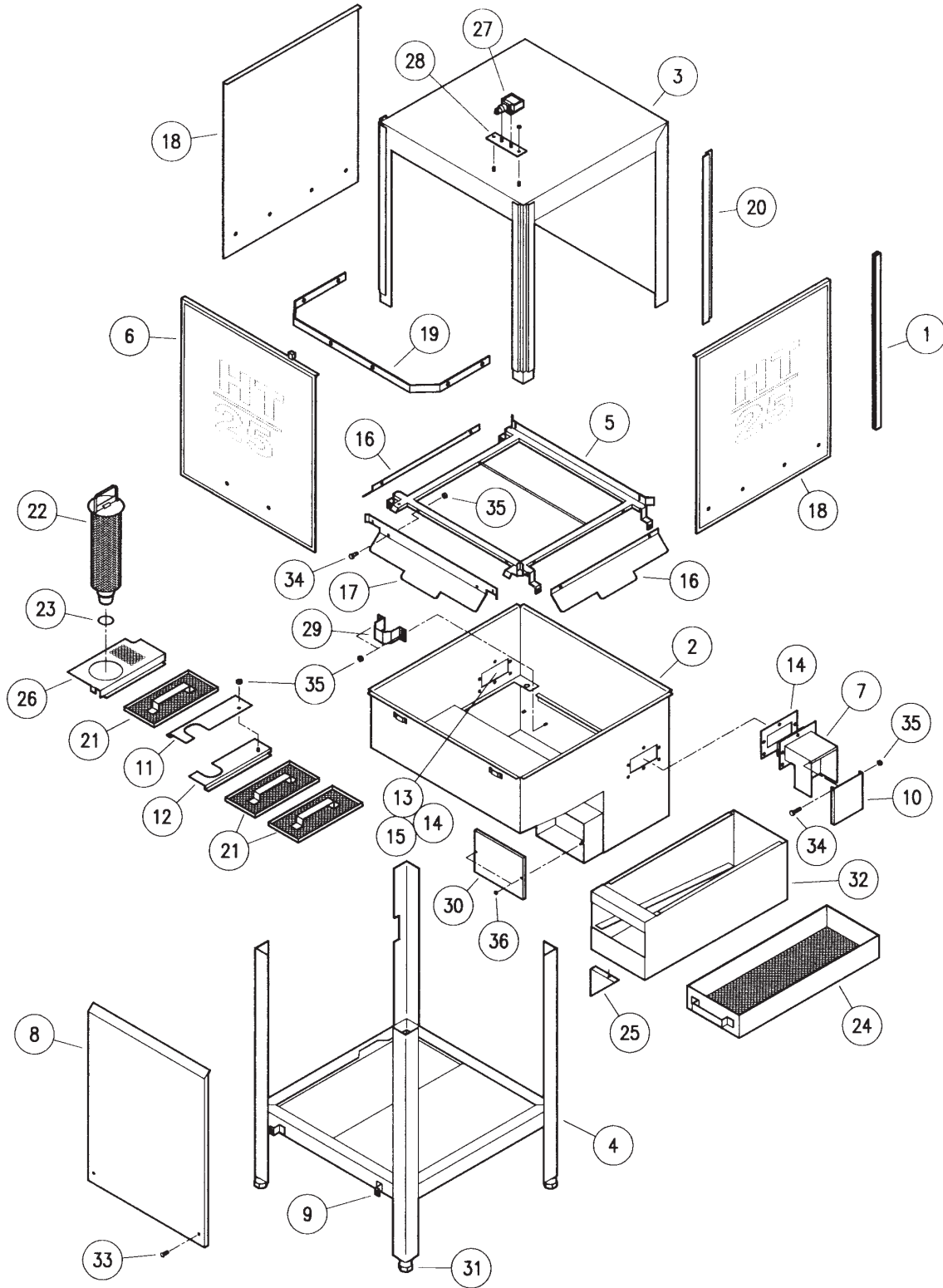

361-0100
Cabinet Assembly
HT-25

American Dish Service

Ref. No.	Part No.	No. Req.	Description
1	383-6101	6	Door Strip, Nylatron
2	385-6101	1	Tank Weldment
3	385-6102	1	Hood Weldment
4	385-6103	1	Frame Weldment
5	385-6104	1	Tray Track Weldment
6	385-6116	1	Door, Front, Weldment
7	385-6120	1	Scrap Trap Chute Weldment
8	385-6123	1	Panel Weldment, Lower
9	385-6127	2	Mount Weldment, Lower Panel
10	386-6014	1	Lid, Scrap Trap Chute
11	386-6016	1	Manifold Cover, LH
12	386-6017	1	Manifold Cover, RH
13	386-6028	1	Plate, Scrap Trap Dummy
14	289-6602	3	Gasket, Scrap Trap Spacer
15	286-6171	1	Spacer Flange, SS
16	387-6009	2	Tray Track Baffle
17	387-6010	1	Tray Track Conversion Bar
18	387-6012	2	Door, Side
19	387-6013	1	Door Brace
20	387-6018	2	Door Guide, SS, (Bolt-On)
21	285-6122	3	Screen Weldment, Wash, Small
22	285-6174	1	Filter Weldment, Wash Pump, W/Taper
23	289-6611	1	Gasket, O-Ring, Wash Taper
24	289-9109	1	Tray, Scrap Trap, Complete
25	289-9114	2	Support, Scrap Trap
26	286-6197	1	Plate, Wash Pump Filter
27	099-4502	1	Switch, Cut-Off
28	285-6103	1	Bracket, Door Cut-Off
29	286-6199	1	Bracket, Float Retainer
30	286-6175	1	Heater Box Cover
31	099-1024	4	Bullet Feet
32	389-9103	1	Scrap Trap Weldment, Without Tray
33	098-1414	20	Bolt, ¼-20 x ½", Truss Head, SS
34	098-1423	30	Bolt, ¼-20 x ½", HH, SS
35	098-2507	50	Locknut, ¼-20, SS
36	098-2201	6	Locknut, 8-32, SS
N/S	384-6118	2	Spacer, Hood Upright
N/S	385-6126	Rep.	Tray Track Assembly, Complete

362-0300
Lower Spray System
Assembly
HT-25

American Dish Service

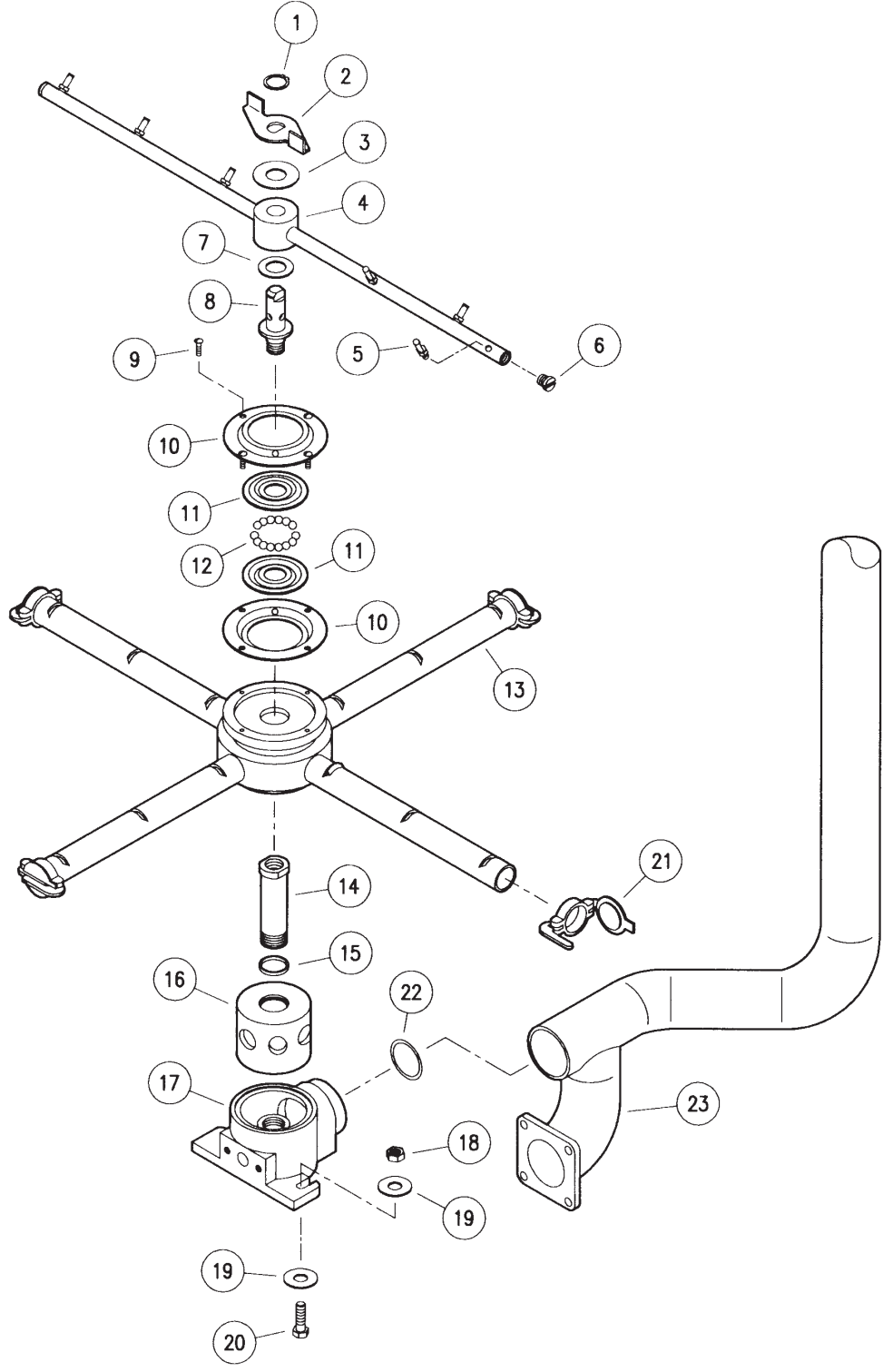

362-0400
Upper Spray System
Assembly
HT-25

American Dish Service

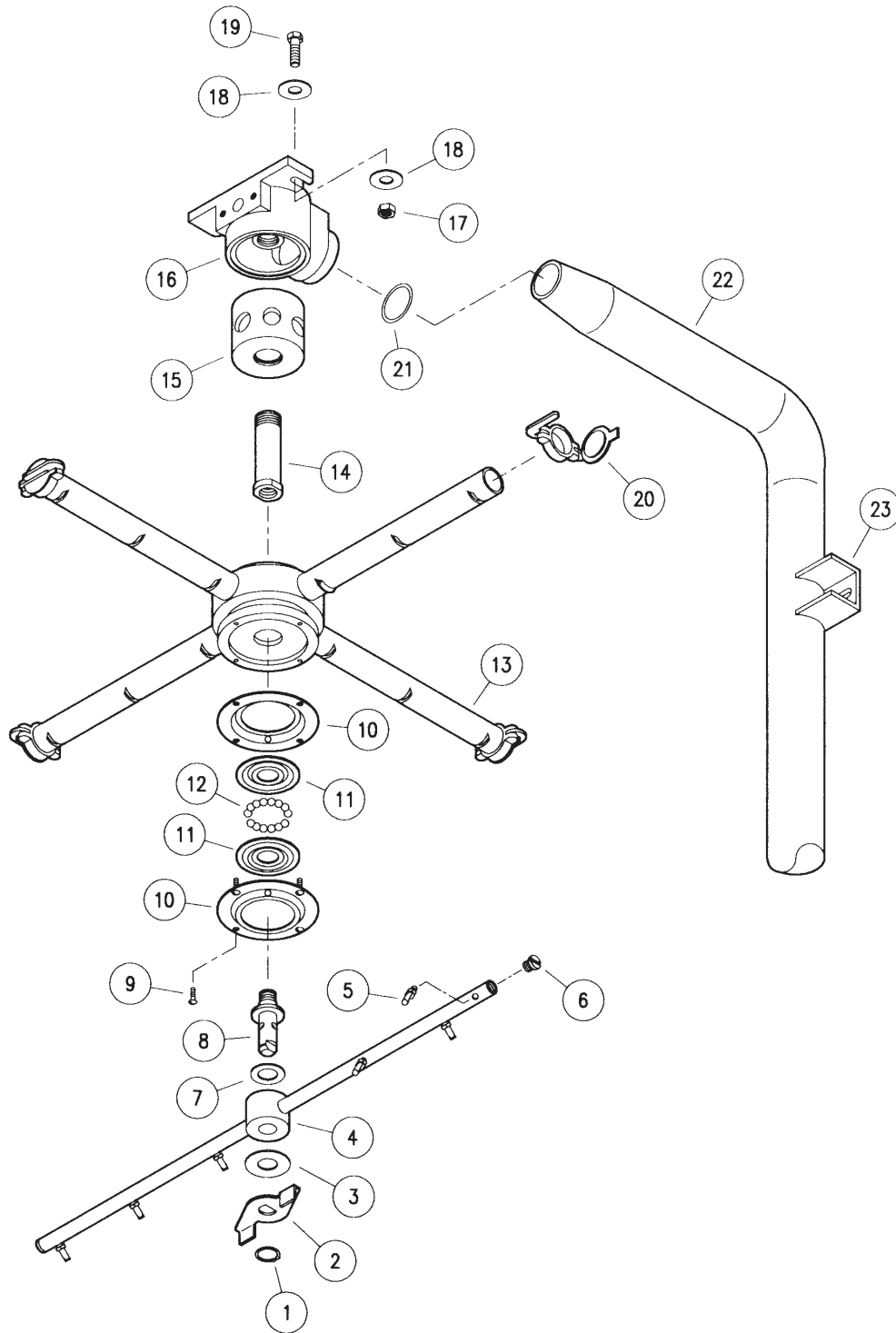

263-0100
Wash Pump Assembly
HT-25/ADC-44

American Dish Service

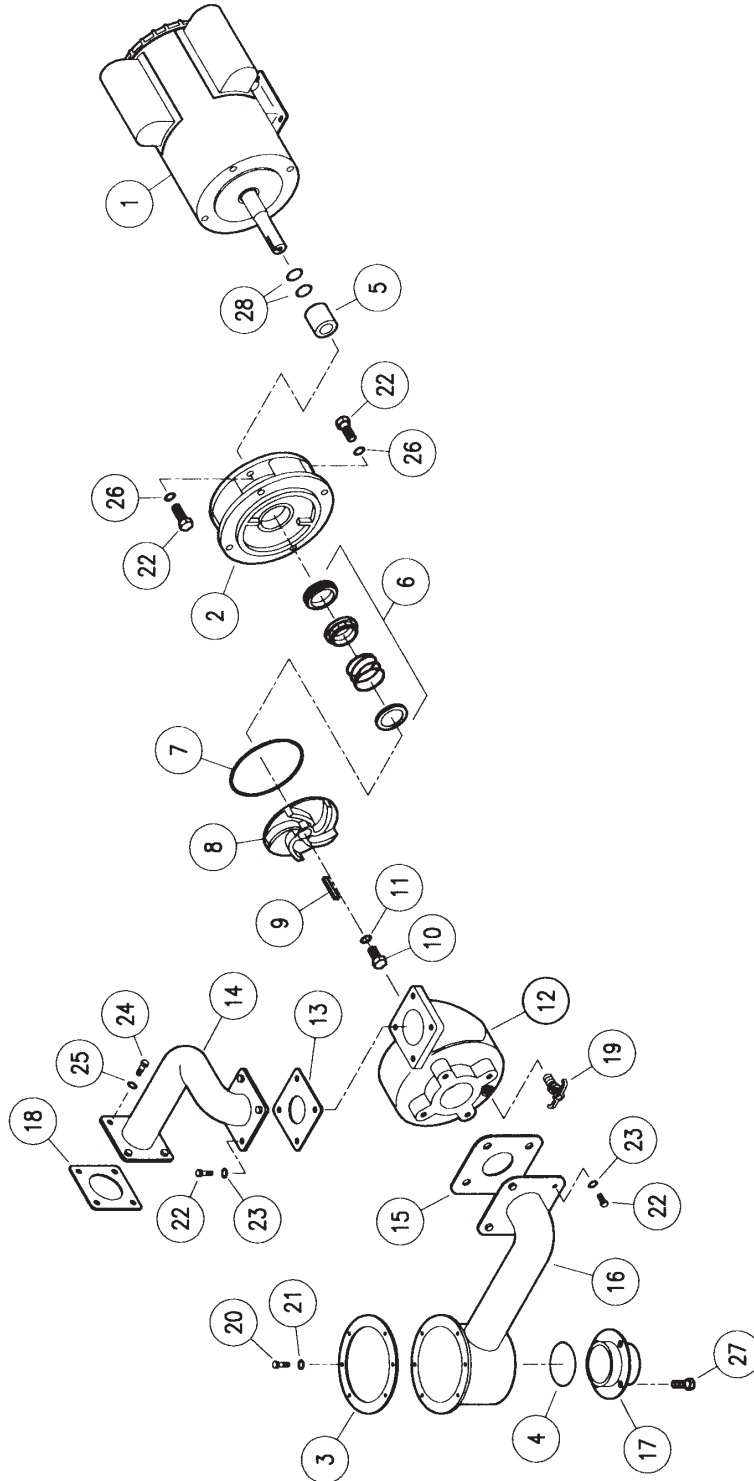

263-0100

Wash Pump Assembly
HT-25/ADC-44**American Dish Service**

Ref. No.	Part No.	No. Req.	Description
1	291-1002	1	Motor, 3HP, 3 Phase w/Shaft
	291-1006		Motor, 3HP, 1 Phase w/Shaft
2	282-6301	1	Housing, Rear, Wash
3	089-6601	1	Gasket, Sump
4	289-6606	1	Gasket, 'O' Ring Drain Socket Flange
5	284-6203	1	Sleeve, Wash Pump Shaft
6	292-2001	1	Seal, Wash Pump
7	289-6603	1	Gasket, Wash Pump 'O' Ring
8	282-6303	1	Impeller, Wash Pump
9	284-6151	1	Key, Wash Pump Impeller
10	098-1613	1	Bolt, 3/8-16 x 1" Lg HH SS w/Lock Strip
11	098-2711	1	Washer, 3/8" ID x 1" OD x .103 Thick SS
12	282-6302	1	Cover, Wash Pump
13	289-6604	1	Gasket, Wash Pump Discharge Flange
14	285-6153	1	Discharge Tube Weldment, Wash Pump
15	289-6605	1	Gasket, Wash Pump Intake Flange
16	285-6154	1	Intake Tube / Sump Weldment, Wash Pump
17	285-6157	1	Drain Socket Weldment, Wash
18	289-6607	2	Gasket, Wash Tank Flange
19	292-1013	1	Petcock, 1/4" mpt
20	098-1423	6	Bolt, 1/4-20 x 1/2" Lg HH SS
21	098-2404	6	Washer, 1/4" SS
22	098-1614	16	Bolt, 3/8-16 x 1" LG HH SS
23	098-2711	8	Washer, 3/8" IDX .103 Thick SS
24	098-1514	4	Bolt, 5/16-18 x 1 1/2" Lg HH SS
25	098-2509	8	Washer, 5/16 SS
26	098-2710	8	Washer, 3/8" Split SS
27	098-1502	4	Bolt, 5/16-18 x 1/2" HH SS
28	289-6618	2	O-Ring, Wash Pump Shaft
N/S	288-1048	Rep.	Pump Assy. Less Cover, Wash 3 HP, 3 PH
N/S	288-1056	Rep.	Pump Assy. Less Cover, Wash 3 HP, 1 PH

364-0100
Control System
Assembly
HT-25

American Dish Service

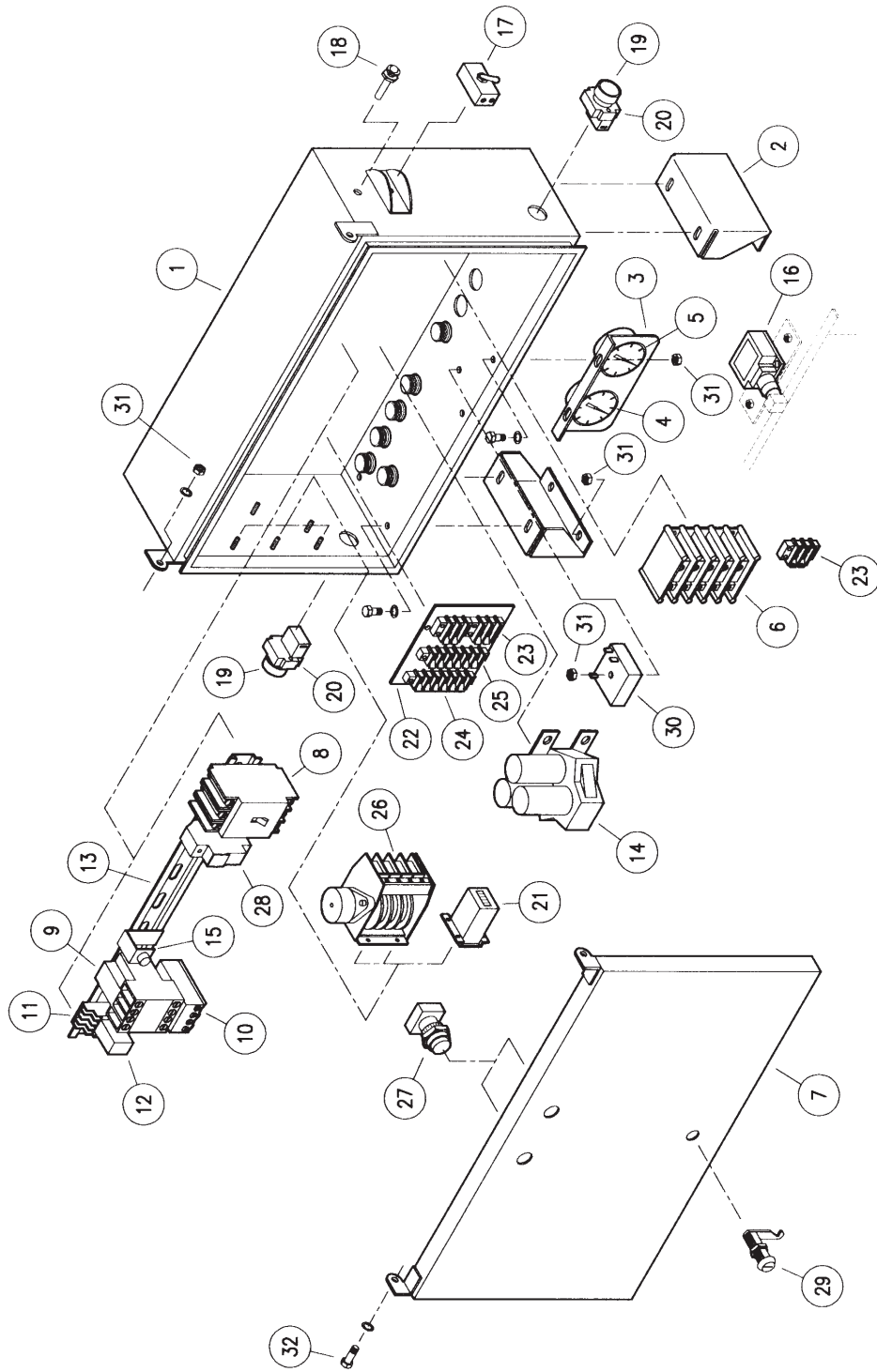

364-0100
Control System
Assembly
HT-25

American Dish Service

Ref. No.	Part No.	No. Req.	Description
1	385-6109	1	Control Box Weldment
2	386-6021	2	Control Box Mounts
3	386-6015	1	Bracket, Temperature Gauge
4	299-1005	1	Gauge, Temperature, Wash Tank
5	299-1004	1	Gauge, Temperature, Final Rinse
6A	391-5101	1	Terminal Block (Main 5 Pole)
6B	291-5101	Opt.	Terminal Block (Main 4 Pole, Single Phase)
6C	291-5105	Opt.	Terminal Block (Main 2 Pole, Single Phase)
7	385-6110	1	Cover Weldment, Control Box
8A	291-3010	1	Circuit Breaker, 50 Amp., 3 Pole
8B	391-3004	Opt.	Circuit Breaker, 60 Amp., 2 Pole (Single Phase)
9	291-3001	1	Contactor
10A	291-3002	1	Overload, 3 HP, 3 Phase
10B	291-3017	Opt.	Overload, 3 HP, 1 Phase
11	291-3009	3	Socket, Relay
12	291-3005	3	Relay, 110 V, Double Pole
13	391-9103	1	Din Rail
14	291-3006	1	Relay, Mercury, 50 Amp., Wash Heater
15	091-7006	1	Light, Heater
16	099-4502	1	Switch, Door Cut-Off
17	091-3008	1	Switch, Master
N/S	291-9105	1	Boot, Master Switch Cover
18	291-7101	1	Light, Indicator
19	091-3067	2	Switch, Push Button, Black
20	091-3065	2	Switch, Contactor
21	091-3049	1	Counter, Electric
22	286-6107	1	Plate, 110V, Terminal Block
23	291-5104	3	Terminal Block, Chemical Dispenser, 2 Pole
24	091-5010	1	Terminal Block, 6 Pole, (White Wires)
25	291-5106	1	Terminal Block, 6 Pole, (Black Wires)
26A	391-3002	1	Timer 60 Sec.
26B	391-3001	Opt.	Timer 45 Sec.
27	391-7102	2	Indicator Light, Wash/Rinse
N/S	391-7101	Opt.	Indicator Light Bulb
N/S	391-7103	Opt.	Indicator Light Lens, Blue
28	391-9101	1	Fuse Holder
N/S	391-9102	1	Fuse, 10 Amp
29	096-1002	1	Control Box Lock
30	091-3059	Opt.	Relay, Auto Start

364-0100
Control System
Assembly
HT-25

American Dish Service

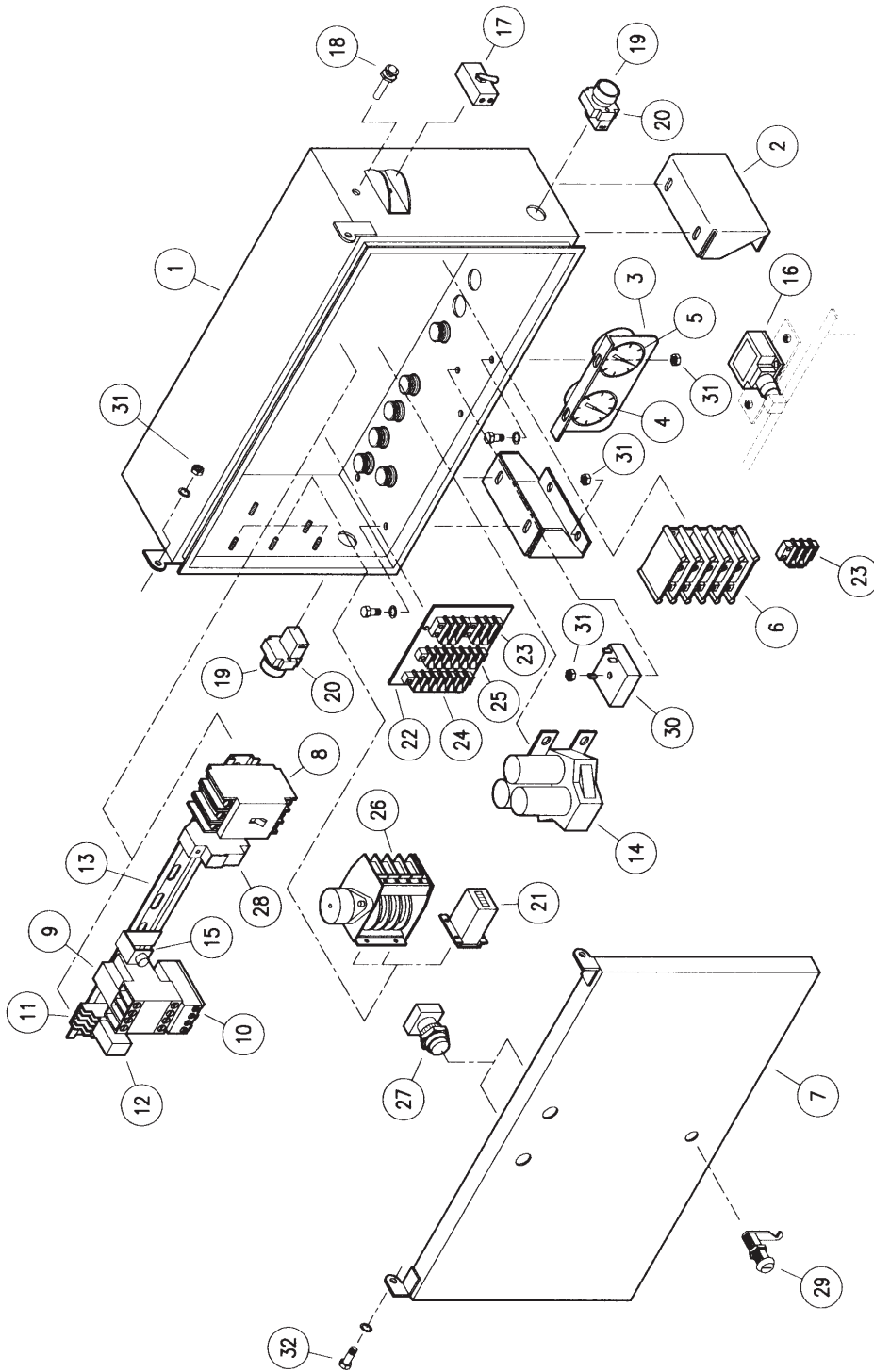

365-0200
Inlet Plumbing
Assembly
HT-25

American Dish Service

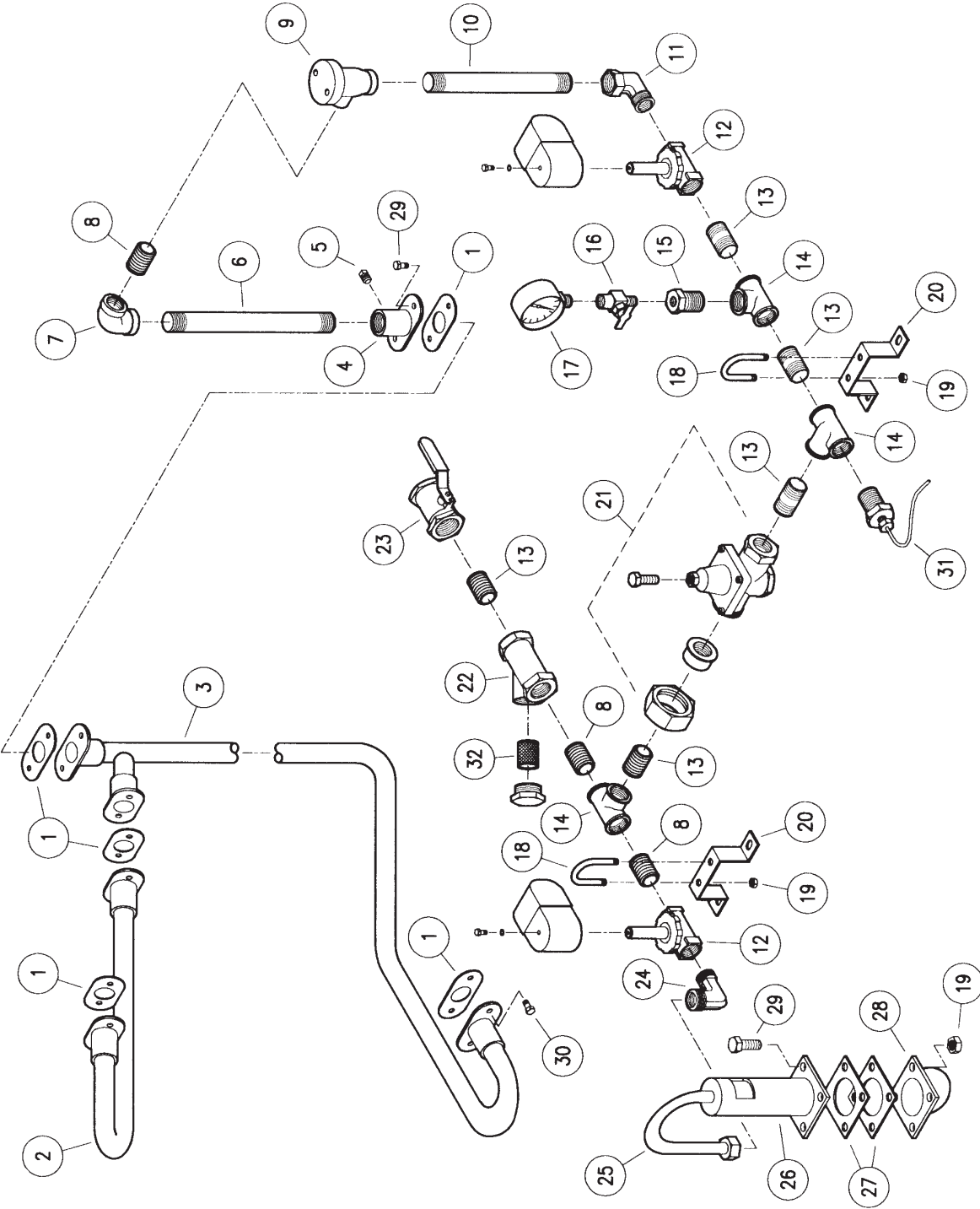

365-0200
 Inlet Plumbing
 Assembly
 HT-25

American Dish Service

Ref. No.	Part No.	No. Req.	Description
1	389-6601	5	Gasket, Final Rinse Flange
2	385-6108	1	Manifold, Rinse, Upper
3	385-6107	1	Manifold, Rinse, Lower
4	385-6128	Opt.	Mixing Chamber (2 Chemical Ports)
5	292-1008	1	Plug, 1/8" NPT, Brass
6	292-3008	1	Nipple, 1/2" x 6" Lg., SS
7	292-1003	1	Fitting, Elbow, 1/2" FPT, SS
8	292-3002	3	Nipple, 1/2" x 1 1/2" Lg., Brass
9	092-5045	1	Vacuum Breaker, 1/2"
10	392-3001	1	Nipple, 1/2" x 4 1/2" Lg., Brass
11	092-1006	1	Fitting, Elbow, 1/2" Street 90 °
12	092-5015	2	Valve, Water Solenoid, 1/2"
13	092-1008	5	Nipple, 1/2" Close, Brass
14	292-1001	3	Fitting, Tee, 1/2" x 1/2" x 1/2", Brass
15	292-1005	1	Reducer Bushing, 1/2" MPT x 1/4" FPT, Brass
16	292-5002	1	Service Cock
17	299-1003	1	Pressure Gauge
18	098-9027	2	U-Bolt, 1/4-20, SS
19	098-2507	18	Locknut, 1/4-20, SS
20	386-6012	2	Bracket, Plumbing
21	292-5001	1	Pressure Regulator, 1/2"
22	092-9001	1	Line Strainer, 1/2"
23	092-5054	1	Ball Valve, 1/2"
24	092-1062	1	Fitting, 1/2" MPT x 1/2" Comp., 90 ° Elbow
25	384-6123	1	Fresh Water Supply Tube
26	385-6121	1	Air Gap Weldment
27	389-6603	2	Gasket, Air Gap
28	385-6124	1	Air Gap Flanged Outlet Elbow Weldment
29	098-1426	8	Bolt, 1/4-20 x 3/4" Lg., HH, SS
30	098-1423	4	Bolt, 1/4-20 x 1/2" Lg., HH, SS
31	299-1004	1	Temperature Gauge, Final Rinse
32	092-9002	Repair	Screen, Line Strainer, 1/2"
N/S	092-5025	Repair	Valve, Less Coil, Water Solenoid, 1/2"
N/S	092-5047	Repair	Kit, Vacuum Breaker Repair, Watts, 1/2"
N/S	092-5049	Repair	Cap, Vacuum Breaker, 1/2"
N/S	092-5051	Repair	Bonnet and Stem, Vacuum Breaker, 1/2"
N/S	292-5003	Repair	Kit, Pressure Regulator, 1/2" Replacement
N/S	092-5016	Repair	Kit, Water Solenoid Valve, 1/2" Replacement
N/S	092-5017	Repair	Coil, Water Solenoid, 1/2" Replacement
N/S	092-5019	Repair	Cap Assembly, Bonnet and Tube, Water Solenoid, 1/2"

368-0100
Heater & Water Level
Control Assembly
HT-25

American Dish Service

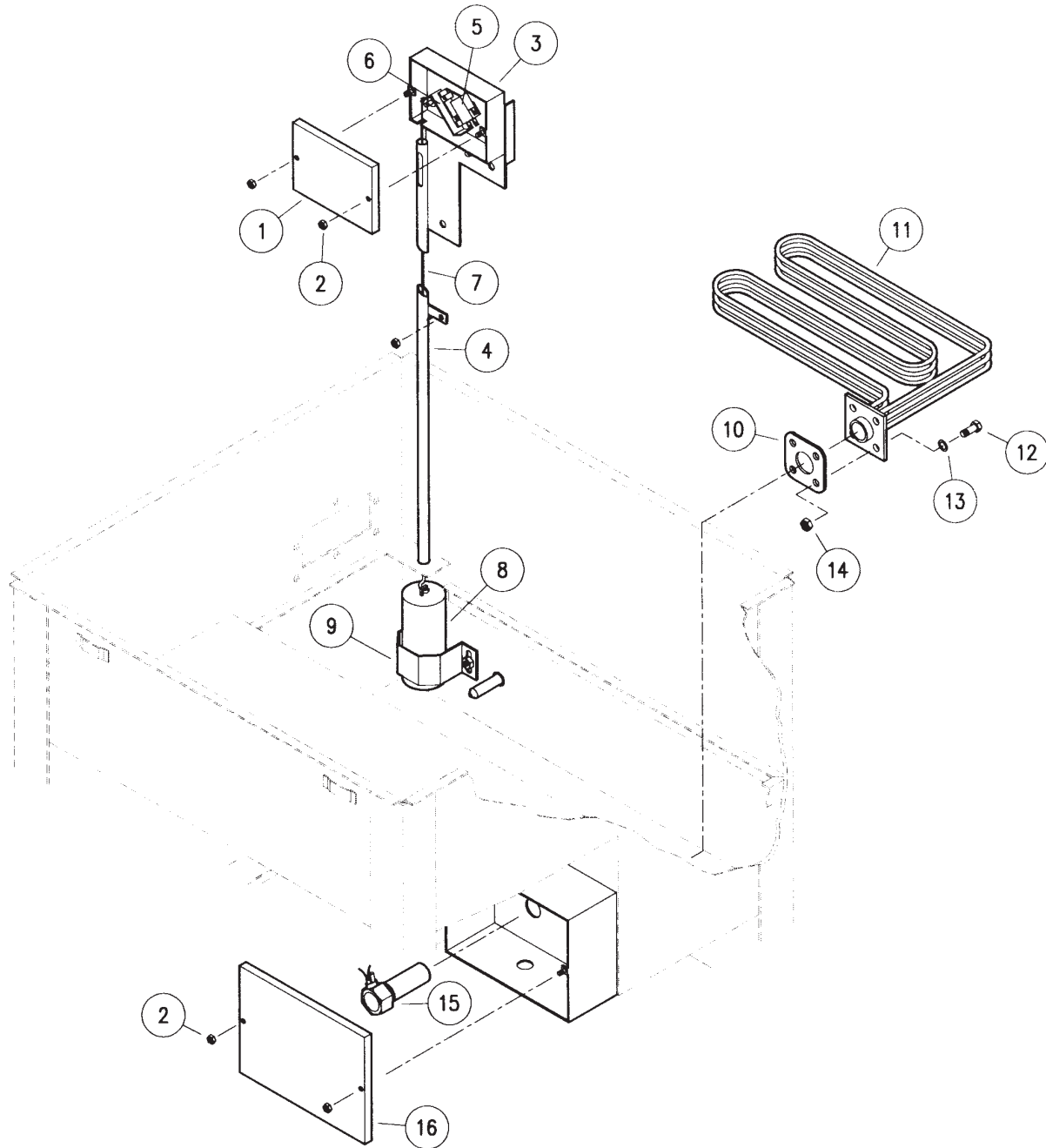

366-0100
Sump & Drain
Manifold Assembly
HT-25

American Dish Service

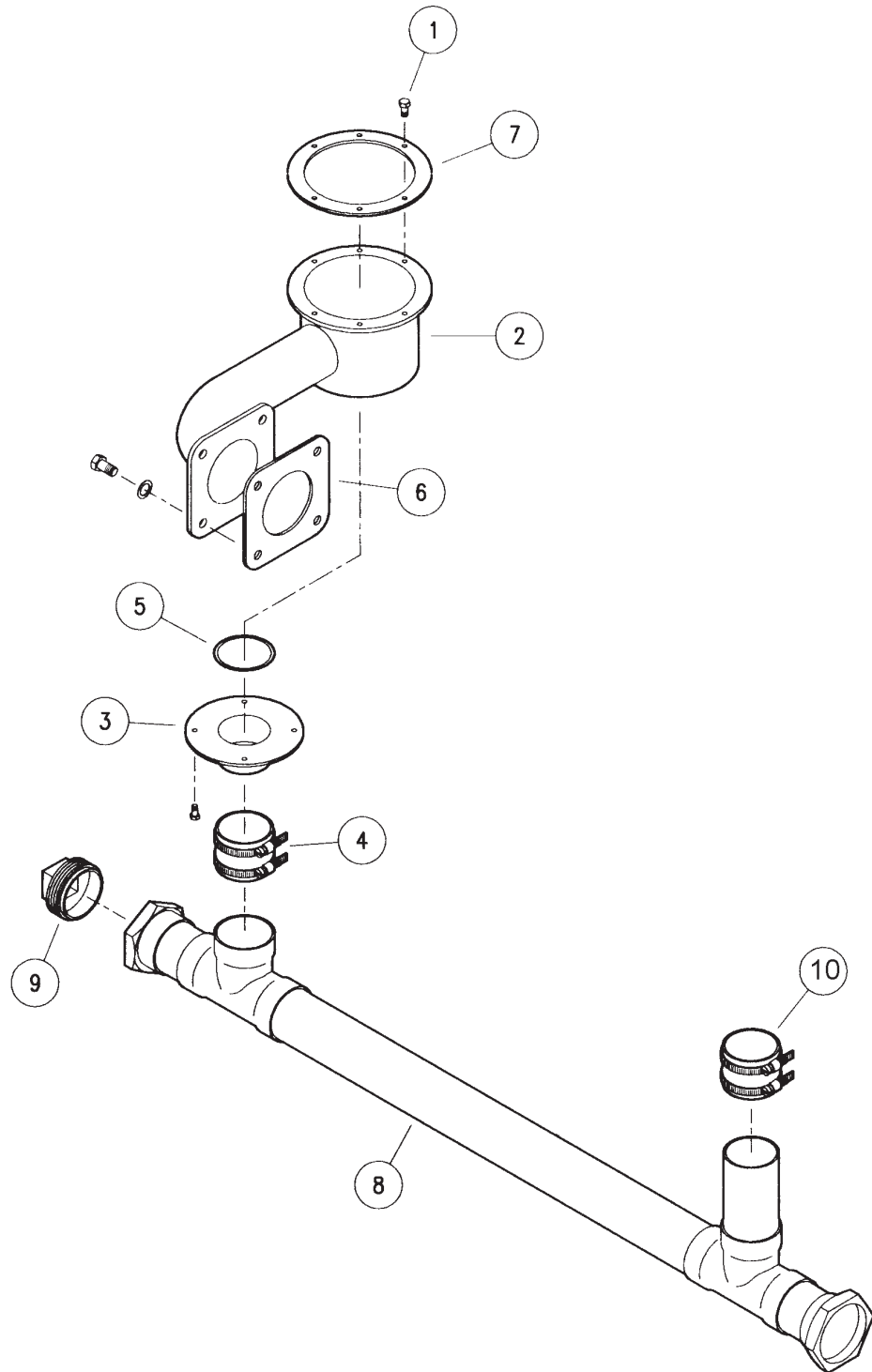

367-0100
Lever Arm Assembly
HT-25

American Dish Service

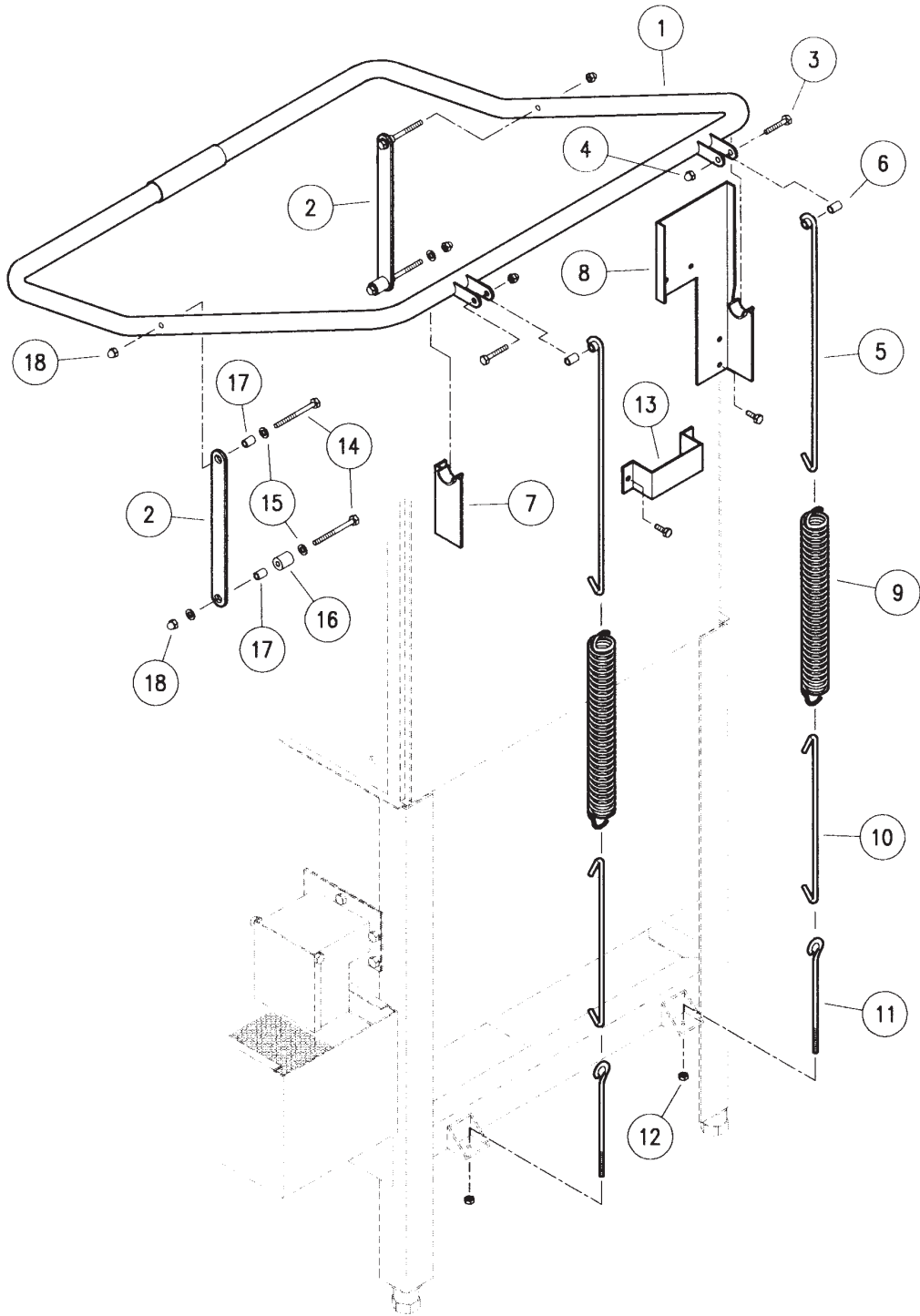

American Dish Service

*Manufacturer of low and high temperature
Commercial Dishwashers and Glasswashers*

900 Blake Street
Edwardsville, Kansas 66111
Phone: (913)-422-3700
Fax: (913)-422-6630